



The City of Clearwater, Florida

Firm Proposal

Mach Alert FSA for Fire Station #47

July 25, 2024

The design, technical, and price information furnished with this proposal is proprietary information of Motorola Solutions, Inc. (Motorola). Such information is submitted with the restriction that it is to be used only for the evaluation of the proposal, and is not to be disclosed publicly or in any manner to anyone other than those required to evaluate the proposal, without the express written permission of Motorola Solutions, Inc.

MOTOROLA, MOTO, MOTOROLA SOLUTIONS, and the Stylized M Logo are trademarks or registered trademarks of Motorola Trademark Holdings, LLC and are used under license. All other trademarks are the property of their respective owners. © 2023 Motorola Solutions, Inc. All rights reserved.

PS-000155178

Motorola Solutions, Inc.
500 W Monroe Street, Ste 4400
Chicago, IL 60661-3781
USA

July 25, 2024

Jeff Walker
City of Clearwater
100 S. Myrtle Ave
Clearwater, FL 33756

Subject: Mach Alert FSA for Fire Station #47

Dear Mr. Walker,

Motorola Solutions, Inc. ("Motorola") is pleased to have the opportunity to provide the City of Clearwater with quality communications equipment and services. The Motorola project team has taken great care to propose a solution that will meet your needs and provide unsurpassed value.

To best meet the functional and operational specifications of this solicitation, our solution includes a combination of hardware, software, and services. Specifically, this solution is for a Mach Alert Fire Station Alerting System for Station 47 and provides:

Mach Alert Station Controller
LED Lighting
Zone Switch
Turn Out Timers
Incident Display Board

This proposal consists of this cover letter, system description, statement of work and pricing. This proposal shall remain valid for a period of 60 days from the date of this cover letter. The City may accept the proposal by delivering to Motorola, a purchase order referencing this proposal (USFL24P182M) and the State of Florida Alternative Contract Source (ACS) 43190000-NASPO contract. Alternatively, Motorola Solutions would be pleased to address any concerns the City may have regarding the proposal. Please note the pricing in this proposal is valid for 60 days.

Any questions can be directed to your Senior Account Manager, Brian Unmisig, at (813)-838-7167.

We thank you for the opportunity to furnish the City of Clearwater with "best in class" solutions and we hope to strengthen our relationship by implementing this project. Our goal is to provide you with the best products and services available in the communications industry.

Sincerely,



Maurizio Callari
Area Sales Manager
Motorola Solutions, Inc.

Table of Contents

Section 1

System Description

Introduction

Integration with Motorola ASTRO 25 IV&D (Integrated Voice & Data) Systems

State Of The Art Fire Station Alerting - Mach Alert Text-to-Speech (TTS) Option

Hardened Systems – Information Assurance

Mach Alert – The Total System Solution

Mach Alert Dispatch Center Hardware

Mach Alert Dispatching Functionality

CAD as the Primary Means of Initiating Alerts

Mach Alert as the Primary Means of Initiating Alerts

Cohabitation of Mach Alert Browser Thin Clients on Motorola Dispatch Consoles

Mach Alert Large System Support

Mach Alert Redundant Dispatch Center Hardware

CAD System Support and MFD-P

Mach Alert CAD System Support Testing Laboratory

Mach Alert Graphical User Interface (GUI) Functionality

Mach Alert Manual or Backup Alerting

Mach Alert Browser Viewing

Concurrent Dispatch Positions

Event Logging

Mach Alert Event and Status Screens

Outdoor Speaker Control

Remote System Access

System Health Monitoring

Alarm Notifications

System Acknowledgments and Logging

Mach Alert GUI System Security

Mach Alert Zone-Based Alerting

Mach Alert Apparatus Alerting

FSA System Transport Functionality

Motorola Radio Systems Supported

IP Network Support

Alerting Over Redundant Communication Links

Data Integrity

Dispatch Operator Voice Announcements

Mach Alert Fire Station Hardware

Mach Alert Station Controller

Station Audio Alerting

Optional System Features

Station Zoning (Audio and Light Zones)

Typical Station System with LED Zoned Lighting

LED Alert Lighting – Optional

Dynamic Zone Selection Switches – Optional

Incident Display Boards (IDBs) – Optional

Turnout Timer (TOT) – Optional

Rip-and-Run™ Thermal Printers – Optional

LED Scrolling Message Boards – Optional

Station Status Touchscreen - Optional

Mach Alert Mobile App – Optional

Standards and Compliancy

Reliability

Multiple Levels of System Redundancy

Section 2

Statement of Work

Section 3

Acceptance Test Plan

Purpose and Scope

System Test Configuration and Equipment Requirements

General Conduct of Testing

Site Inspections and Tests

System Performance and Verification Tests

FSA System Functional Tests

Section 4

Service/Warranty

Section 5

Pricing Summary

Section 6

Contractual Documentation

System Description

This Section describes the general features and options available for the Mach Alert Fire Station Alerting (FSA) system and is not project-specific.

Introduction

The *Mach Alert* Fire Station Alerting (FSA) system serves as a cornerstone for the successful operation of the dispatch alerting process. This microprocessor-based alerting system will help manage resources with proven hardware and software, leading to a reduction in emergency response times, less firefighter stress, and the confidence your stations will be alerted every time.

Fire Services, now more than ever, are facing newer and greater challenges. System operating flaws, breakdowns, problematic interfaces, and alerting delays are unacceptable. Proven technology, communications compatibility, software customization, and an intuitive user interface are mandatory.

The *Mach Alert* FSA system is designed for fast response, integration with existing infrastructure, redundancy, and the ability to gracefully migrate into the latest technologies and new features. It utilizes innovative design allowing installations to be tailored to your specific Fire and EMS needs.

The *Mach Alert* FSA system does not depend on PC hardware at the stations for its fundamental fire station operation. It utilizes Motorola's new ACE3600 high-performance controller offering enhanced reliability. As the lead component in our fire station alerting system, it meets these challenges head-on.



Motorola ACE3600 Remote Terminal Unit

The *Mach Alert* FSA system is capable of interfacing with IP-based CAD (Computer Aided Dispatch) systems to provide automated fire station alerting. *Mach Alert* provides a backup or

manual means of alerting the fire stations if the CAD system is unavailable. If there is no CAD system present, *Mach Alert* FSA functions as the primary means of alerting the fire stations. The dispatch operator can easily access the *Mach Alert* System and its associated Graphical User Interface (GUI) via a thin browser client on a Windows-based PC. The browser allows the dispatcher to manually select the sequence, station(s) and zones required for the alert.

In a request from the City of Clearwater, FL, Motorola Solutions Inc. is pleased to propose a Mach Alert Fire Station Alerting system that includes hardware at one new Fire Station #47:

The new equipment in this quote includes:

Base System – Fire Station:

- One (1) Mach Alert Station Controller
- (28) LED Light Fixtures connected to five (5) LED lighting controllers
- One (1) Incident Display Board
- Ten (10) Zone Selector Switches
- Four (4) Turn out Timers

Integration with Motorola ASTRO 25 IV&D (Integrated Voice & Data) Systems

While the *Mach Alert* System supports legacy Motorola Radio Systems, it was specifically designed for integration with the Motorola ASTRO 25 IV&D System and its associated state of the art dispatch consoles.

- The *Mach Alert* System is annually tested and verified for operation on the Motorola ASTRO 25 IV&D System for every new release.
- The *Mach Alert* System is annually tested for cohabitation on both the Motorola MCC7500 and MCC7100 Dispatch Operator Consoles.
- *Mach Alert* currently operates on numerous Motorola ASTRO 25 IV&D systems in North America.

Hardened Systems – Information Assurance

To comply with Federal Government regulations for hardened systems, Information Assurance (IA) is required. *Mach Alert* meets these stringent regulations as follows:

- *Mach Alert* complies with multiple federal agencies' Information Assurance (IA) policies including those required for military bases.
- *Mach Alert* is tested and validated against the Motorola MotoPatch CD every month to ensure that all *Mach Alert* systems can be patched to the high standards set by Motorola.

Mach Alert – The Total System Solution

This “Total System Solution” consists of an Alerting Interface Controller (AIC), FSA Server, and Station Controllers (SC) as shown in the following figure. These components are described and their functionality presented in the ensuing sections. Available options to enhance the basic system are also provided.

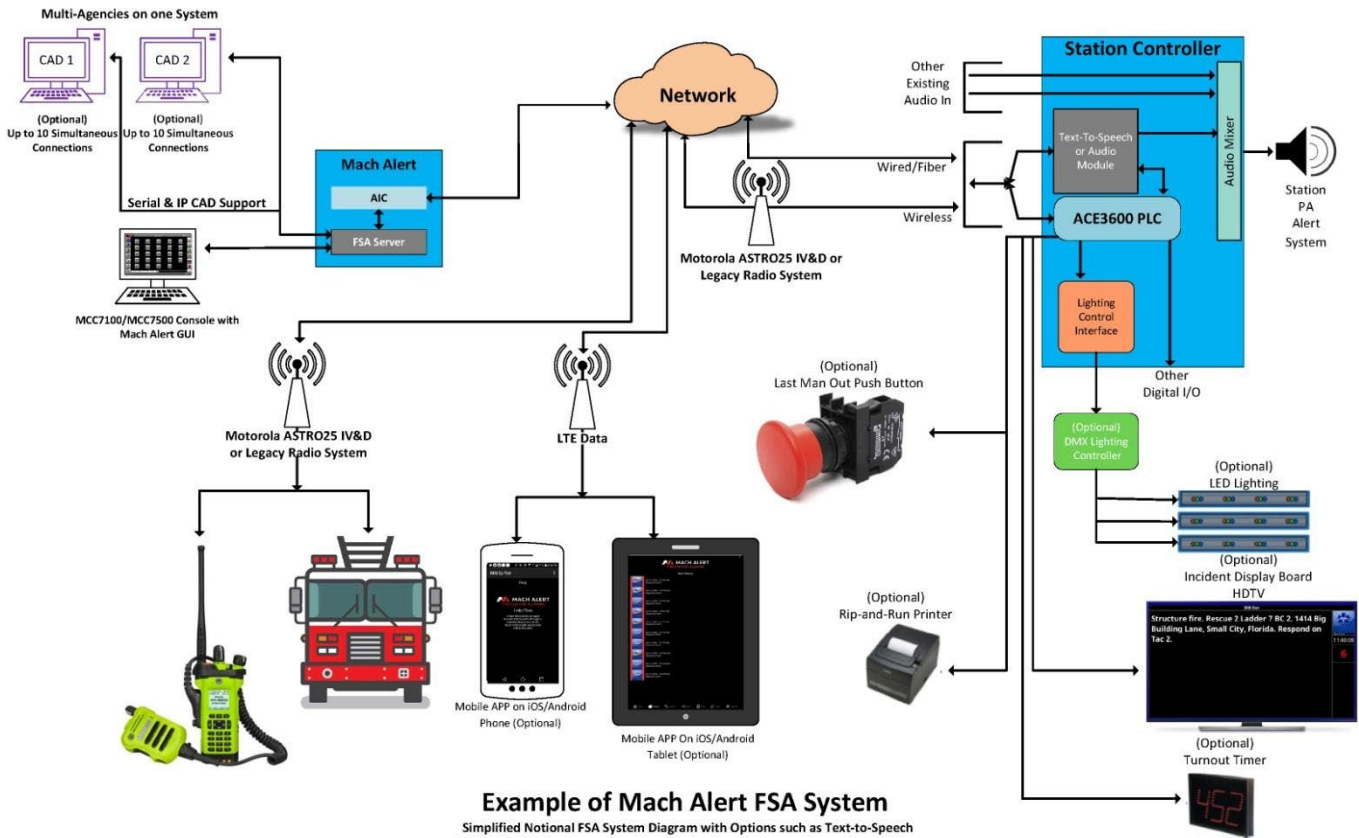

Example of Mach Alert FSA System
Simplified Notional FSA System Diagram with Options such as Text-to-Speech (TTS), LED Lighting Control, Incident Display Board, Turnout Timer, Rip-and-Run Printer and Mobile App

Mach Alert FSA Typical System Diagram

Mach Alert Dispatch Center Hardware

The *Mach Alert* Dispatch Center hardware consists of the *Mach Alert* FSA Server and Alerting Interface Controller (AIC). The dispatch operation is typically located at the Emergency Communications Center.

- The *Mach Alert* FSA Server hosts the primary *Mach Alert* software and provides a Graphical User Interface (GUI) to the fire station alerting system. The *Mach Alert* GUI is accessed using browser thin clients that normally cohabitate on the Motorola Dispatch Consoles but may also be located on separate dispatch operator terminals if required. The server also manages dispatch operator manual station alerting, automated optional text-to-speech incident announcements, remote system access, and system alarm and event logging. The server also provides the interface to the customer IP network for alerting over that network.
- The *Mach Alert* AIC is the fire station alerting interface to the Motorola Radio System. The Alerting Interface Controller is a Motorola ACE3600 high-performance controller that provides the means of communicating the alerting data over the radio network to the *Mach Alert* Station Controllers (SCs) located at the fire stations. The AIC also sends the alerting data over the IP network to provide redundancy to the FSA Server in the event it is offline.

Mach Alert FSA Typical Dispatch Center Hardware

The following diagram shows the mounting of the FSA Server and the AIC on a standard 19" equipment rack. This equipment is usually located at the Dispatch Center.

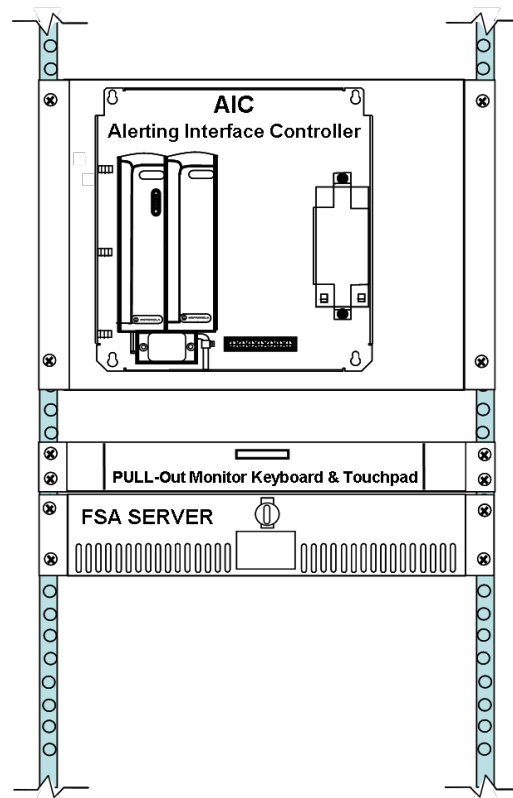

FSA System Transport Functionality

This section addresses the *Mach Alert* functionality over the various possible transport media. *Mach Alert* supports numerous Motorola Radio Systems in addition to IP networks.

Motorola Radio Systems Supported

The *Mach Alert* FSA system has multiple integrated communications ports allowing it to utilize various Motorola Radio Systems dedicated to fire station alerting (not voice). *Mach Alert* supports alerting over the following Motorola Radio Systems:

- 700/800 MHz IV&D Digital Trunking*
- UHF R2 (450-520 MHz) Band IV&D Digital Trunking*
- UHF R1 (380-470 MHz) Band IV&D Digital Trunking*
- VHF IV&D Digital Trunking*
- 800 MHz Analog Trunking
- RF Conventional UHF Analog
- RF Conventional VHF Analog

IP Network Support

In addition to alerting over the Motorola Radio System, *Mach Alert* also supports Ethernet IP Networks utilizing customer enterprise connectivity between the Dispatch Center(s) and the fire stations. Please note that minimum bandwidth requirements must be met in order to provide reliable Ethernet link connectivity. These bandwidth requirements are available upon request.

Alerting Over Redundant Communication Links

The *Mach Alert* FSA system supports up to two (2) redundant communications links for station alerting (data) and an independent communications link for announcements (voice). The system design offers a “high-availability” fire station alerting operation through multi-level redundancy.

Both the existing IP network and the existing radio system can be used to alert the fire stations. Station alerting is transmitted over the redundant communications links concurrently. The key point here is that the *Mach Alert* FSA system does not have to make a selection if one link fails, as is often the case with PC-based systems. This assures the alert data will reach each fire station controller selected to be alerted with minimal delays. Alerting over Redundant Communication Links meets NFPA 1221 requirements.

Motorola highly recommends utilizing two redundant communications links for station alerting when using ASTRO IV&D which ensures a highly responsive and highly reliable alerting solution. In the event that the IP link fails, alerting is still supported by the IV&D system. The IV&D system has a lower bandwidth than wired IP and when used in backup mode supports an alerting cadence of approximately 3 seconds per station for alerts to be received and acknowledged.

If the radio system used for alerting is offline, station alerting will be processed using the IP network. If the Ethernet link used for alerting is offline, station alerting will be processed using the radio link.

If the radio link or the IP network link fails to the fire stations, the *Mach Alert* System will continue to function, including toning, CAD processing, backup dispatch, zoning, event logging, and failure notifications. The system meets NFPA 1221 recommendations.

At the fire station, the Station Controller activates the alert tones based on data received on the first (quickest) link and does not process data from the other link. However, both the radio and IP communication links send an acknowledgment (“ACK”) back to the AIC to verify that both communication links are operational. ACKs are also sent to the CAD system, if present, for updating. After the alert tones are played, the dispatch operator can begin the voice announcement.

Mach Alert supports the following combination of alerting links:

- One (1) Ethernet link and one (1) Radio System (Trunking or Conventional) link
- Two (2) Radio System (Trunking and/or Conventional) links
- Two (2) Ethernet links

Note that two data links are required for NFPA1221 Compliancy.

Data Integrity

The *Mach Alert* FSA system utilizes the Motorola Data Link Communications (MDLC) protocol specifically designed for data over radio networks. It creates a true wireless network environment that provides maximum data integrity. The MDLC protocol is based on the Open System Interconnection (OSI) model recommended by the International Organization for Standardization (ISO). MDLC utilizes all seven layers of the OSI model and is designed for point-to-multipoint links such as an FSA system. MDLC provides optimum operation in saturated RF environments. The protocol facilitates communications among all sites in the system, including extensive diagnostic messaging. CRC-32 level data detection is provided. The MDLC protocol is also used to ensure data integrity over Ethernet for alerting via the AIC over the IP network.

Dispatch Operator Voice Announcements

The dispatch operator voice announcements are sent on a separate and independent radio talk group/channel. The same Motorola Radio Systems that are supported for alerting is also supported for voice announcements.

Mach Alert Fire Station Hardware

The following sections detail the *Mach Alert* Hardware that is available for installation in the fire stations.

Mach Alert Station Controller

The *Mach Alert* Station Controller (SC) is a Motorola ACE3600-based high-performance RTU installed in a NEMA-1 wall-mount industrial panel. The SC is located at each fire station typically in a communications utility room. The SC processes information to and from the AIC and FSA Server, generates alert tones and provides station audio control including optional text-to-speech decoding.

The Station Controller (SC) is a modular unit containing the following hardware:

- Motorola ACE3600 Power Supply Module.
- Motorola ACE3600 CPU Module.
- Motorola ACE3600 Digital Input/Output Module - additional modules are available to support additional I/O functionality.
- Optional Motorola Radio(s) – space is provided within the SC to house one (1) Motorola Alerting Data Radio and (1) Motorola Voice Radio.
- Integrated 6.5 Ah Backup Battery.
- An XLR audio input is provided to interface with an optional external voice radio.
- A balanced line-level audio output connection is provided to interface with the fire station PA amplifier.
- A Tones module for the storage of audio tones. 35+ default tone library pre-loaded. Custom tones are supported.
- Optional TTS Module for in-station TTS.
- Audio mixer and audio relays to control the flow of audio to the station PA system.
- Live audio sensing device.
- 4-port Ethernet switch.
- Support for external Turnout Timers.
- 8 Digital Output Relays standard – may be purchased with up to 40 Output Relays for additional output control.
- 8 Digital Input Terminal Blocks standard – may be purchased with up to 24 Terminal Blocks for additional monitoring capability.
- Depending on the options purchased, the SC may also house supporting hardware for the LED Zoned Lighting System and Zone Selector Switches.
- Transient Voltage Surge Suppression.
- Automatically resets after an alert is completed in preparation for the next alert.

Below is a mechanical design view of the *Mach Alert* Station Controller:

Station Controller

Mechanical Design Concept

Sample Installed Custom SC System

- Motorola Data Radio or IV&D
- 12V Battery Back-Up
- Motorola Voice Radio
- Network switch
- Smart Switch Controller (Option)
- Tones Module
- TTS Module (Option)
- Audio Mixer
- Audio Detector
- DMX Lighting Module (Option)

Mach Alert Station Controller

Station Audio Alerting

The *Mach Alert* Station Controller hardware and software automatically controls the alerting process. When stations are alerted, unique alert tones are played over the station's PA system. To prevent additional stress, these tones are ramped ("heart saver"); that is, they start at low volumes and escalate in volume to a desired level for a specific period of time. The tones can also be unique based on incident type, apparatus, company, and/or personnel. They can include a combination of tone and recorded voice. Custom, user-supplied tones are a standard feature of the system design. Toned alerting meets NFPA 1221 recommendations.

Mach Alert provides several available options for providing audio to the fire station.

- An Audio Tones Module supplies ramped alert tones and a brief pre-recorded voice alert designating for the type of alert, followed by opening the station PA system for the dispatch operator to verbally alert personnel. This is a standard feature of *Mach Alert*.
- An optional Text-to-Speech (TTS) function can translate a CAD generated text string containing specifics of the alert message (or a type-written message generated via the dispatcher if there is no CAD in the system, or it is unavailable) into human-voice quality speech and transmit it over the IP network to the Station Controller as a compressed audio file for playback after completion of the locally stored alert tone.
- A TTS Over-the-Air (OTA) option is also available to provide the TTS announcement over the Motorola Radio System as opposed to over the IP network.

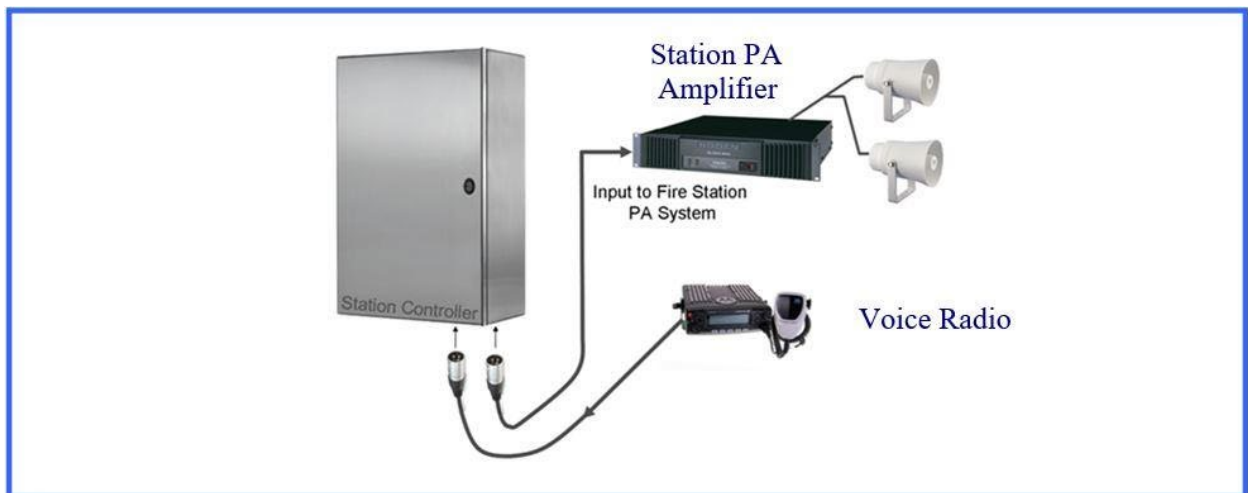

Mach Alert Station Audio

Optional System Features

Optional fire station auxiliary functions can be added to the *Mach Alert* FSA system to further enhance how a department responds to emergencies. Auxiliary functions may include, but are not limited to the following:

- *Mach Alert* Mobile App
- Incident Display Boards – Quoted as an Option
- Zoned LED Lighting – Quoted as an Option
- Turnout Timers
- “Rip-and-run” Thermal Printers
- LED Scrolling Message Boards
- Station Status Touchscreen
- Opening bay doors
- Manual acknowledgment to dispatch that the station was alerted
- Manual acknowledgment to dispatch that the first responder has exited the station
- Automating exhaust systems
- “Safe Zone” doorbells can be heard over the PA system
- Appliance shut-off (automatic upon alert or button push)
- Station audio and lighting zones
- Bunkroom zoning
- Monitoring station intrusion alarms
- Control of traffic signals
- Monitoring generators (on/off, failures)
- Status of appliances (on or off)
- Status of fire station alerting equipment
- Weatherproof NEMA-4, NEMA-4X, or extra-large enclosure options

Station Zoning (Audio and Light Zones)

The *Mach Alert* FSA system supports the partitioning of fire stations into specific zones, each receiving specific types of alerts. The *Mach Alert* System can accommodate zone partitioning based on the individual needs of each fire station. It supports zoned alerting with ramped custom tones, ramped LED bunkroom lighting, apparatus bay and common area alert lighting, egress lighting, and automated outdoor speaker control (day/night modes). Also, as options, the *Mach Alert* System supports the control of fire station lights, Incident Display Boards, Turnout Timers, plus other custom features designed for a fire department’s specific needs.

Typical Station System with LED Zoned Lighting

The diagram below shows a typical *Mach Alert* Station Controller-based system with options implemented for alert lighting and audio as well as zone selection switches.

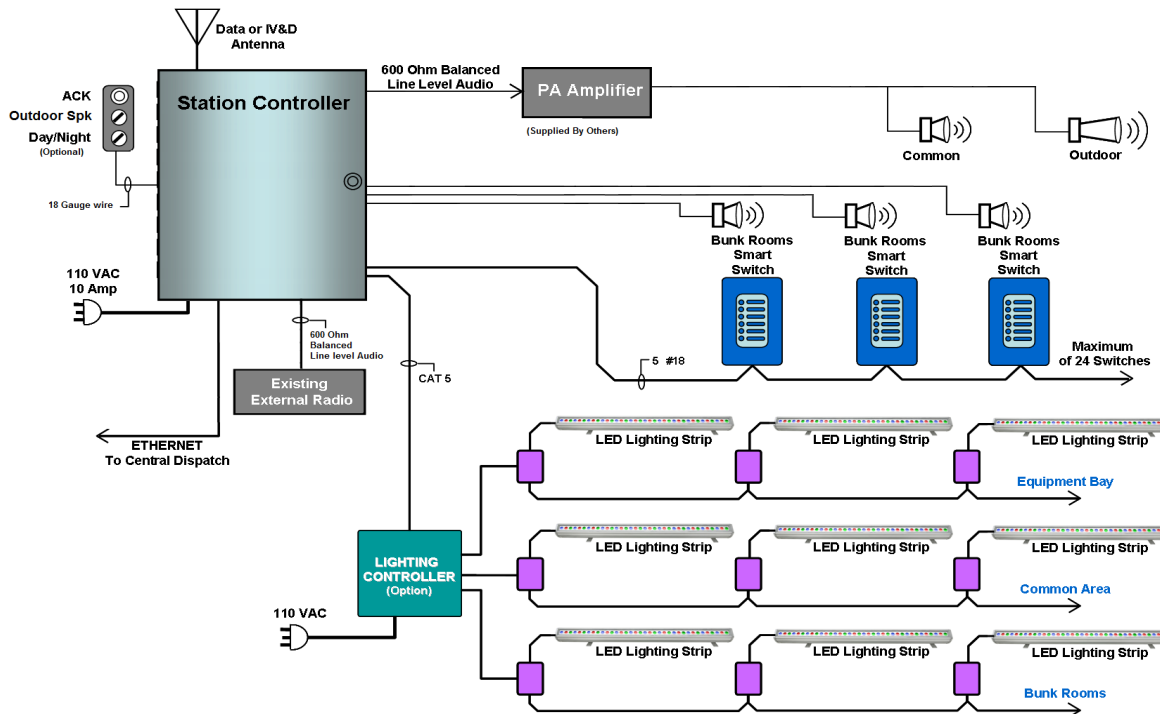

LED Alert Lighting

The optional use of LED lighting strips for the FSA installation are for visual alerting in addition to the audio alert (PA) system. The RGB lighting strip is compatible with a commercially available controller. LED lighting strips are activated and controlled in various colors and sequences to alert station personnel of conditions and warnings.

The optional LED lighting is connected to the Station Controller. The LED lighting can be configured for ramp time, maximum intensity and colors.

Bunkroom LED lighting is ramped. Each bunkroom can have a LED light strip that will activate based on the type of alert. For example, if the bunkroom is reserved for the engine, the LED strip can be set to ramp to a red display. If the bunkroom is reserved for rescue, the LED strip can be set to ramp to a blue display. These high-intensity, RGB color LED strips can also be used in the common areas, bays, weight rooms, outside, offices, etc. When used in the hallways, they provide adjustable soft white egress lighting.



Mach Alert LED Lighting Option

Dynamic Zone Touch Pads

If a department desires to have the flexibility of using their bunkrooms based on specific personnel, apparatus, and/or company, wall switches may be provided as an option, allowing each bunkroom (or Zone) to select the type of alert, or combination of alerts, to be directed to that bunkroom. Fire or EMS personnel can use any bunkroom and select their specific alert(s) to be directed to that room. LED indicators on the wall switch indicate which alerts have been selected, or no alerts.

Example Zone Selection



More than one zone can be selected such as BC & Rescue

- **Rescue-** This room will receive Rescue, All Call, & Announcement
- **Engine-** This room will receive Fire, All Call, & Announcement
- **Assistant Chief (AC)-** This room will receive Assistant Chief, All Call, & Announcement
- **Battalion Chief (BC)-** This room will receive Battalion Chief, All Call, & Announcement
- **Light-** This Rooms Night light will be on when lighting controller is in Night Light Mode
- **Vacant-** This room will not receive any Calls

Note: If no Zones are selected Room will receive every call

Mach Alert Zone Selector Switch

Incident Display Boards (IDBs)

IDBs can be provided for each fire station as an option. High Definition (HD) LED or LCD monitors can be provided and configured to display incoming alert incident information based on input from the CAD system (for example, units responding, address/location, incident type, cross streets, etc.) When alerted, the displays present a screen border color-coded to indicate the call type. A “count-down” and “count-up” timer is displayed indicating the amount of turnout time left and the amount of time past the required departure. The count-down timer is yellow. When it indicates 00, it turns red for the count-up time. If Internet access is granted, a map of the incident location can also be displayed on the IDB.

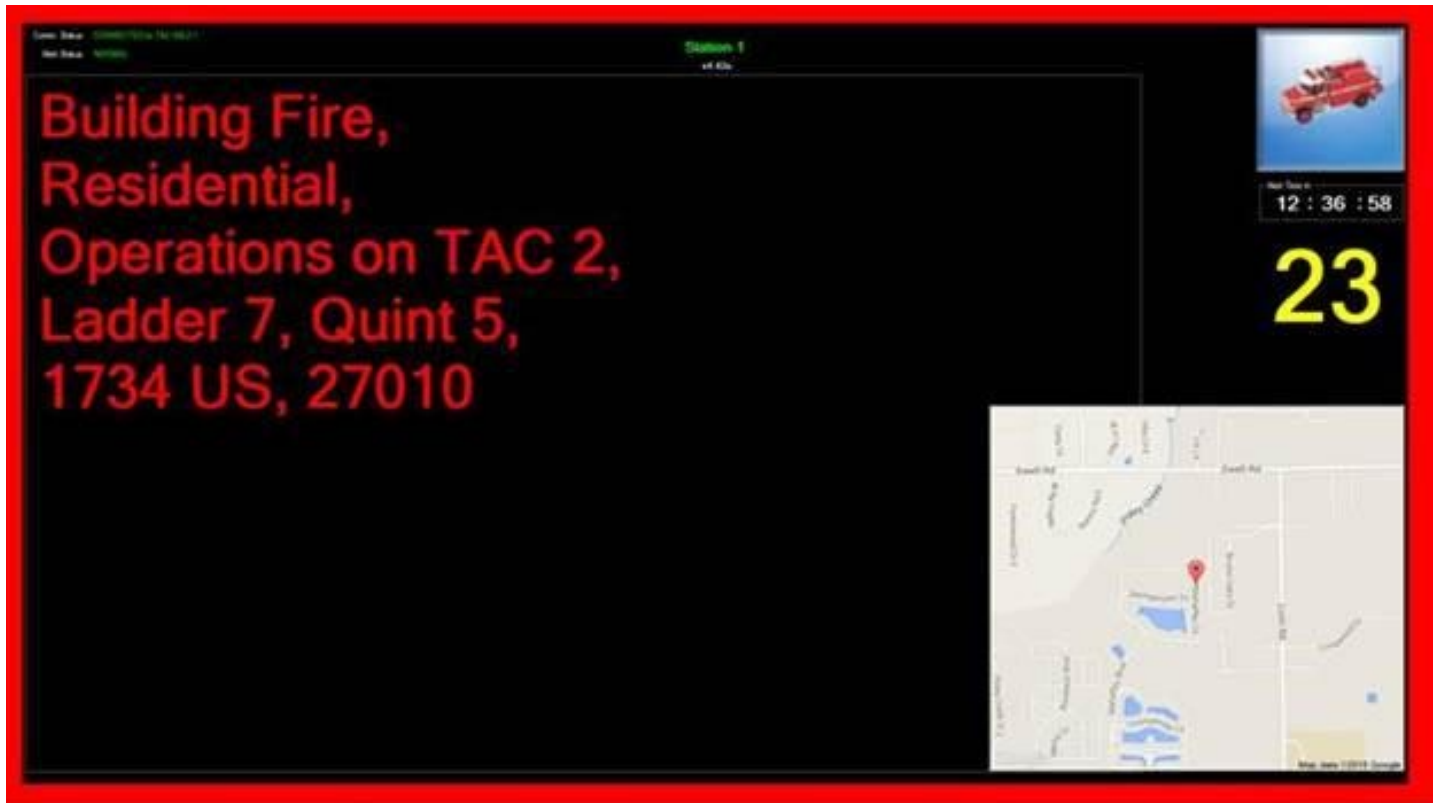

Mach Alert Incident Display Board

Turnout Timer (TOT)

The *Mach Alert* system can trigger an optional wall-mounted turnout timer when an alert is received. The TOT has configurable settings that allow for the adjustment of the countdown time interval. The countdown time is also configurable based on alert type and can be automatically reset upon the next alert or can be reset through an external (optional) pushbutton. The display is a 3-digit LED display that has a character viewing distance of 125 feet.



Mach Alert Turnout Timer

Section 2

Statement of Work

This Statement of Work (SOW) describes the most current understanding of the work required by Motorola Solutions, Inc. ("Motorola") to provide a successful implementation of a MACH Alert Fire Station Alerting (FSA) system.

It is understood that this SOW may be revised during contract negotiations or during the Detailed Design Review (DDR), and through any other Change Orders that may occur during the execution of the project.

Motorola is pleased to propose the MACH Alert Fire Station Alerting System (FSA) for Clearwater, FL for installation at Fire Station #39.

The following sections detail specific responsibilities of the Customer and Motorola in general and during various project phases. Motorola is responsible for coordinating and ensuring proper execution.

	Motorola Solutions	Clearwater, FL
PROJECT INITIATION		
Contract Finalization and Team Creation		
Execute contract and distribute contract documents.	X	X
Furnish a performance bond in the full amount of the contract price as security for the faithful performance of Motorola Solutions' contractual obligations.	X	
Purchase the required performance bond.		X
Assign a Project Manager as a single point of contact.	X	X
Assign resources.	X	X
Schedule project kickoff meeting.	X	X
Deliverable: Signed contract, defined project team, and scheduled project kickoff meeting.		
Project Administration		
Ensure that project team members attend all meetings relevant to their role on the project.	X	X
Set up the project in the Motorola Solutions information system.	X	
Record and distribute project status meeting minutes.	X	
Maintain responsibility for third-party services contracted by Motorola Solutions.	X	
Maintain responsibility for third-party services contracted by Clearwater		X

	Motorola Solutions	Clearwater, FL
Complete assigned project tasks according to the project schedule.	X	X
Submit project milestone completion documents.	X	
Upon completion of tasks, approve project milestone completion documents.		X
Conduct all project work Monday thru Friday, 8:00 a.m. to 5:00 p.m.).	X	
Deliverable: Completed and approved project milestones throughout the project.		
Project Kickoff		
Introduce team, review roles, and decision authority.	X	X
Present project scope and objectives.	X	
Review SOW responsibilities and project schedule.	X	X
Schedule Design Review.	X	X
Deliverable: Completed project kickoff and scheduled Design Review.		
Design Review		
Review the Customer's operational requirements.	X	X
Present the system design and operational requirements for the solution.	X	
Present installation plan.	X	
Present preliminary cutover plan and methods to document final cutover process.	X	
Present configuration and details of sites required by system design.	X	
Validate that Customer sites can accommodate proposed equipment.	X	X
Provide approvals required to add equipment to proposed existing sites.		X
Review safety, security, and site access procedures.	X	
Finalize site acquisition and development plan.	X	
Present equipment layout plans and system design drawings.	X	
Provide backhaul performance specifications and demarcation points.		X
Provide information on existing system interfaces.		X
Assume liability and responsibility for proving all information necessary for complete installation.		X
Assume responsibility for issues outside of Motorola Solutions' control.		X
If necessary, complete the required forms required for frequency coordination and licensing.	X	
Ensure that frequency availability and licensing meet project requirements, and pay licensing and frequency coordination fees.		X

Statement of Work

Use or disclosure of this proposal is subject to the restrictions on the cover page.
Motorola Solutions



	Motorola Solutions	Clearwater, FL
Review and update design documents, including System Description, Statement of Work, Project Schedule, and Acceptance Test Plan, based on Design Review agreements.	X	
Provide minimum acceptable performance specifications for customer provided hardware, software, LAN, WAN and internet connectivity.	X	
Execute Change Order in accordance with all material changes to the Contract resulting from the Design Review.	X	
General Installation		
Perform Equipment Inventory and Delivery to Customer Sites	X	
Coordinate receipt of and inventory solution equipment with designated contact.	X	
Provide system interconnections that are not specifically outlined in the system design, including dedicated phone circuits, microwave links, or other types of connectivity.		X
Install and terminate all network cables between site routers and network demarcation points, including microwave, leased lines, and Ethernet.	X	
Ensure that Type 1 and Type 2 AC suppression is installed to protect installed equipment.		X
Label equipment, racks, and cables.	X	
Note any required changes to the installation for inclusion in the "as-built" system documentation.	X	
Remove, transport, and dispose of old equipment.		X
Provide an Ethernet network connection with a minimum throughput of 512 Kbps from Fire Station 1 to the FSA server located in the Dispatch facility.		X
Deliverable: Solution equipment received and ready for installation.		
Fire Station Installation		
Install Station Controller	X	
Provide and pull all required cabling and wiring, termination ends and cable management, hardware as needed along with conduit in bay areas as required.		X
Provide mounting hardware, support strut, and required fasteners to SC	X	
Provide one Category 6 Ethernet feed(s) to SC from customer network switch		X
Provide two (2) 18 AWG TSP Shielded audio line from SC to PA amplifier		X
Land all Ethernet connections into assigned switch ports predetermined by the City of Clearwater		X
Land audio line into assigned input on PA amp, determine best spot if needed		X
Install LED Lighting Hardware	X	
Provide and pulls all required wiring and cabling, termination ends, and cable management hardware as needed along with conduit in bay areas as required		X
Install twenty-eight (28) LED Light Fixtures (LLF) connected to five (5) LED Lighting	X	

Statement of Work

Use or disclosure of this proposal is subject to the restrictions on the cover page.
Motorola Solutions



	Motorola Solutions	Clearwater, FL
Controllers (LC)		
Terminate and one (1) Category 6 Ethernet feed to primary LC and terminate Category 6 feeds to subsequent LCs and LLFs		X
Plug LC into local duplex AC outlets and terminate all Category 6 cabling for all LCs and LLFs		X
Install Zone Selector Switches	X	
Provide and pull all required cabling and wiring, termination ends and cable management, hardware as needed along with conduit in bay areas as required.		X
Provide all required Category 6 cabling, termination ends, and cable management hardware as needed along with nominal conduit/wire mold if required to connect all ZSS back to the fire network switching the IT closet all individually homerun wired for each ZSS.		X
Terminate, and test audio cables for ten (10) existing speakers for audio zoning to SC		X
Provide and install four (4) Turn out Timers in designated locations	X	
Terminate, and test one (1) 18/6 shielded cable (provided by the City of Clearwater) from Turn Out Timer to SC for signal and power		X
Provide all required Cabling, termination ends, and cable management hardware as needed along with conduit in bay areas as required		X
Deliverable: Equipment installed.		
Functional Acceptance Testing		
Verify the operational functionality and features of the solution supplied by Motorola Solutions, as contracted.	X	
Witness the functional testing.		X
Document all issues that arise during the acceptance tests.	X	
If any major task for the system as contractually described fails during the Customer acceptance testing or beneficial use, repeat that particular task after Motorola Solutions determines that corrective action has been taken.	X	
Resolve any minor task failures before Final System Acceptance.	X	
Document the results of the acceptance tests and present for review.	X	
Review and approve final acceptance test results.		X
If any major task as contractually described fails, repeat that particular task after Motorola Solutions determines that corrective action has been taken.	X	
Document all issues that arise during the acceptance tests.	X	
Document the results of the acceptance tests and present to the Customer for review.	X	
Resolve any minor task failures before Final System Acceptance.	X	

	Motorola Solutions	Clearwater, FL
Deliverable: Completion of functional testing and approval by Customer.		
PROJECT TRANSITION		
Training		
Finalize schedule for training coursework.	X	
Provide training facility.		X
Ensure that the training participants fulfill course prerequisites.		X
Conduct the training classes outlined in the Training Plan.	X	
Attend proposed training classes.		X
Deliverable: Training coursework completed.		
Cutover		
Finalize Cutover Plan.	X	X
Provide programming of user radios and related services (i.e. template building, re-tuning, testing and installations), as needed, during cutover period.		X
Conduct cutover meeting with relevant personnel to address both how to mitigate technical and communication problem impacts to the users during cutover and during the general operation of the system.	X	
Notify the personnel affected by the cutover of the date and time planned for cutover.		X
Provide ongoing communication with users regarding the project and schedule.	X	X
Cut over users and ensure that user radios are operating on system.		X
Resolve punchlist items, documented during the Acceptance Testing phase, in order to meet all the criteria for final system acceptance.	X	
Assist Motorola Solutions with resolution of identified punchlist items by providing support, such as access to the sites, equipment and system, and approval of the resolved punchlist items.		X
Deliverable: Migration to new system completed, and punchlist items resolved.		
Transition to Warranty		
Review the items necessary for transitioning the project to warranty support and service.	X	
Motorola Solutions to provide services during year 1 warranty which align with the proposed services.	X	
Provide a Customer Support Plan detailing the warranty support associated with the contract equipment.	X	
Participate in the Transition Service/Project Transition Certificate (PTC) process.		X

Statement of Work

	Motorola Solutions	Clearwater, FL
Deliverable: Service information delivered and approved by Customer		
Finalize Documentation and System Acceptance		
Provide manufacturer's installation material, part list and other related material to Customer upon project completion.	X	
Provide an electronic as-built system manual on CD or other Customer preferred electronic media. The documentation will include the following: <ul style="list-style-type: none"> ● System Level Diagram. ● Site Block Diagrams. ● Site Equipment Rack & Enclosure Configurations. ● System Acceptance Test Plan Test Sheets and Results. ● Equipment Inventory List. ● Product Manuals. ● Drawings will be delivered in PDF format. 	X	
Receive and approve documentation.		X
Execute Final Project Acceptance.	X	X
Deliverable: All required documents are provided and approved. Final Project Acceptance.		

Assumptions

Motorola has made several assumptions in preparing this proposal, which are noted below. In order to provide a firm quote, Motorola will need to verify all assumptions or seek alternate solutions in the case of invalid assumptions.

- All existing sites or equipment locations will have sufficient space available for the system described as required/specified by R56. All sites will meet Motorola Solutions' R56 2005 Standards for Communications sites. If the customer does not have a copy of the "R56 v.2005 Standards & Guidelines for Communications site," one will be provided by Motorola Solutions.
- All existing sites or equipment locations will have adequate electrical power in the proper phase and voltage, and site grounding to support the requirements of the system described. Adequate backup power is available to support the proposed equipment. Existing generators, if available, have adequate capacity to support the equipment.
- Any site/location upgrades or modifications are the responsibility of Clearwater.
- Approved local, State, or Federal permits as may be required for the installation and operation of the proposed equipment are the responsibility of Clearwater.
- Any required system interconnections not specifically outlined here will be provided by Clearwater. These may include dedicated phone circuits, microwave links, or other types of connectivity.
- No coverage guarantee is included in this proposal.
- Motorola is not responsible for interference caused or received by the Motorola-provided equipment except for interference that is directly caused by the Motorola-provided transmitter(s) to the Motorola-provided receiver(s). Should Clearwater's system experience interference,

Statement of Work

Motorola can be contracted to investigate the source and recommend solutions to mitigate the issue.

- If Clearwater chooses to purchase the optional Incident Display Board functionality it is assumed that the City will be providing the HDMI monitors. Monitors must have a HDMI input and a 2 gang 120V AC outlet must be within 3' of the mounting locations inside the fire stations. If the City does not have a 2 gang 120V AC outlet within 3' of their desired mounting location MSI can quote the required electrical work as part of a change order.
- Customer is currently utilizing a A7.17.2 ASTRO system release with expectation to fully upgrade to system release in 2023. The customer should understand that current system release is past standard support and in extended support.
- MACH ALERT thin clients to be installed upon existing MCC 7500 positions. (NOTE: Thin clients licenses are only intended to be utilized in the event the customer CAD system were to fail, otherwise all primary alerting begins within CAD).
- Interfacing software API (Application Program Interface) is accomplished by employing the Motorola Fire Dispatch Protocol (MFD-P).
- Computer Automatic Dispatch (CAD) will need to support Motorola Fire Dispatch Protocol (MFD-P 7.35) and requires CAD vendor support for implementation. Customer will need to enlist the services of the CAD vendor to provide their support. Mach Alert, Inc. does not directly enlist the services of the CAD vendor. Mach Alert is willing to work with the CAD Vendor to develop a SOW for their quote, and will allow them to test on their demo system in Tampa.
- IV&D is presumed to be the responsibility of the MASTER site for the City, and no IV&D or Enhanced Data services are listed for purchase by Clearwater to implement MACH ALERT on their sites. Ethernet IP Network, customer enterprise connectivity between the dispatch center(s) and the fire stations.

Network Design Diagram and Specific Assumptions

The following is a system overview, as understood by discussions on shared site services between the City of Clearwater ASTRO CORE RNI site. The network connectivity presumes the MACH ALERT FSA server, AIC, and CAD server are co-located at the ASTRO CORE RNI site, which reduced the need for using the existing MW loop to connect the Dispatch site with the EOC site via a network e-pipe. All terrestrial IP network connectivity between Dispatch and Fire Station #1 are maintained and serviced by the customer's IT network team. At a future date, should the customer elect to add a IP link between the EOC and station 2, it would only require a reconfiguration of MACH ALERT server, but not additional HW.

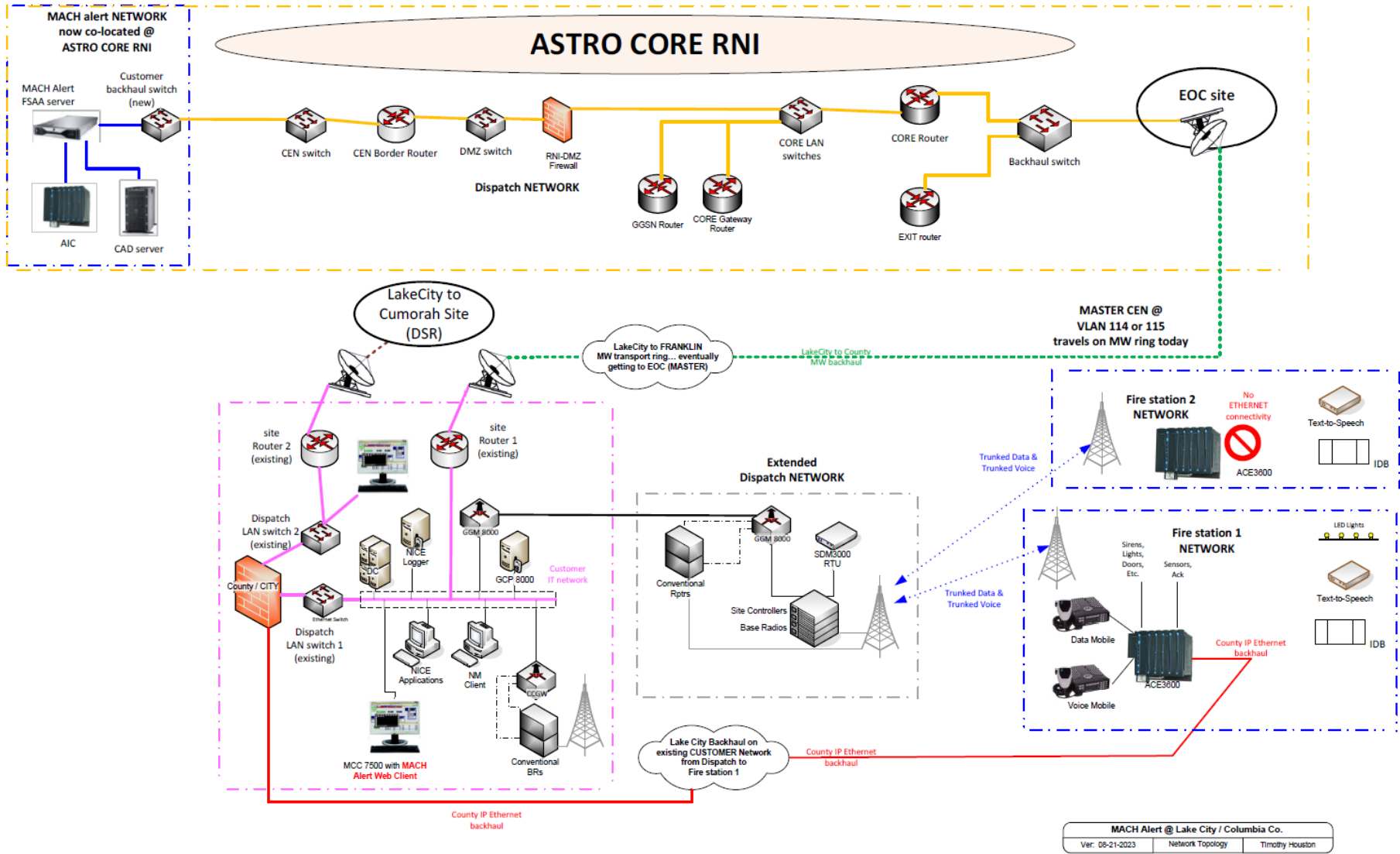

Statement of Work

Use or disclosure of this proposal is subject to the restrictions on MOTOROLA SOLUTIONS
Motorola Solutions

Section 3

Acceptance Test Plan

System Acceptance of the proposed solution will occur upon successful completion of a Functional Acceptance Test Plan (FATP), which will test the features, functions, and failure modes for the installed equipment in order to verify that the solution operates according to its design. This plan will validate that Clearwater's solution will operate according to its design, and increase the efficiency and accuracy of the final installation activities. A detailed FATP will be developed and finalized during project implementation.

An example of a standard Mach Alert FATP is included below.

MACH ALERT FIRE STATION ALERTING

ACCEPTANCE TEST PLAN (ATP)¹

Purpose and Scope

The Field Acceptance Test Plan (ATP) will be performed by Mach Alert, Inc. (Mach Alert) and Motorola Solutions, Inc. (Motorola). The purpose of the ATP is to verify the basic operation, functionality, and installation quality of the MACH Alert FSA system. The ATP has been designed to validate the ability of the system to deliver the designed and contract required system functionality to end users. System functions and features not included within this ATP plan will not be tested. Successful completion of the Field ATP will fulfill the Final Acceptance requirements. The ATP provides a brief description and a list of the tests, which will be executed with end user representatives. The actual Test Procedure sheets will be provided to the end user before the scheduled start of the Field Test. In addition to the functional tests covered in the ATP, the ATP will include site and installation related tests.

Site Inspections and Tests

The following items will be checked to verify the installation quality and configuration of the system Dispatch and Fire Station sites. The site installations should conform to Motorola's R56 Installation Quality Standards where applicable.

1. Equipment inventory and configuration.
2. Dispatch equipment room rack availability, location, and rack layouts.
3. Fire station equipment room SC mounting options and space availability, Ethernet connectivity, lighting controls, PA amplifier interface, and audio connection to the end user provided voice radio.
4. 120 V electrical power source.
5. Grounding and bonding.
6. AIC and Server interfaces with CAD.

¹ This document describes a general Acceptance Test Plan for the *MACH Alert* Fire Station Alerting and Automation (FSA) solution and is not project specific. The project specific ATP will be developed during the Detailed Design Review (DDR) phase of the project.

7. The Radio Dispatch Console system browser thin client interface to the FSA Server.

System Performance and Verification Tests

System Performance and Verification testing is performed during the Field Acceptance Test phase and is designed to verify the performance / operation of the FSA subsystems and site installations as outlined in this ATP. System Performance and Verification Tests will be completed for the following:

1. Network equipment and interfaces.
2. Dispatch center equipment and software.
3. End-to-end FSA station alerting.

FSA System Functional Tests

Functional Testing is included in Field Testing phases and is designed to verify the required FSA system functionality and features.

Section 4

Service/Warranty

Motorola's standard 1 year warranty applies to all Motorola equipment.

Motorola has included the option to purchase Mach Alert's extended Hardware and Software support warranty. This pricing can be found in Section 6 - Pricing Summary. The pricing for these services is broken out depending on which additional MA options the City elects to purchase.

Pricing Summary

Motorola is pleased to provide the following equipment and services to the City of Clearwater, FL.

Description	Price (\$)
Equipment	\$52,854
Implementation and Warranty Services	\$100,517
Subtotal	\$153,371
<i>Contract Discount</i>	<i>(\$10,571)</i>
<i>System Discount</i>	<i>(\$4,484)</i>
Total System	\$138,316

Warranty Summary

Description	Price (\$)
Warranty Year 2	\$9,128
Warranty Year 3	\$9,128
Warranty Year 4	\$9,128
Warranty Year 5	\$9,128

This proposal is subject to the terms and conditions of Motorola Solutions' NASPO contract and this pricing is valid through September 23, 2024.

Payment Milestones

Except for a payment that is due on the Effective Date, Customer will make payments to Motorola within thirty (30) days after the date of each invoice. Customer will make payments when due in the form of a check, cashier's check, or wire transfer drawn on a U.S. financial institution. If Customer has purchased additional Professional or Subscription services, payment will be in accordance with the applicable addenda. Payment for the System purchase will be in accordance with the following milestones.

System Purchase

1. **50% of the System Price due upon contract execution (due upon effective date); and**
2. **50% of the System Price due upon Final Acceptance.**

Section 6

Contractual Documentation

The products and services shall be provided under the terms and conditions of the State of Florida Alternative Contract Source (ACS) 43190000-NASPO contract.